

OWNERS MANUAL

SPHERE SYNEXIS SYSTEM



Contents

| | |
|---|----|
| About Synexis® Dry Hydrogen Peroxide (DHP®) | 2 |
| Indications for Use, Legal, Patent Info | 3 |
| Welcome, Included Parts | 4 |
| System Specifications | 5 |
| General Safety Instructions | 6 |
| Device Placement | 7 |
| Installation | 8 |
| Troubleshooting, Maintenance | 11 |
| Getting the Most from Your DHP System | 12 |
| Safety Considerations | 13 |

About Dry Hydrogen Peroxide (DHP™)

Synexis® is the sole developer of hydrogen peroxide gas and Dry Hydrogen Peroxide (DHP™) Technology for occupied spaces. Using DHP, our patented microbial reduction technology allows for the natural and continuous reduction of microbial contamination in occupied spaces. Our microbial reduction systems are patented for use in the United States and around the world. By encompassing all areas of an enclosed space, DHP can reach the most important areas of a facility. The critical differentiator of DHP from other forms of hydrogen peroxide is that DHP can be safely delivered in occupied spaces.

Using ambient humidity and oxygen naturally present in your environment, our technology creates a safe level of hydrogen peroxide (H_2O_2) gas, which reduces unwanted microbial contamination in the air and on surfaces. Because DHP is a true gas, it can reach the toughest and most out-of-reach areas of your facility. Dry Hydrogen Peroxide is effective because of its state of matter and method of action.

Indications for Use

This product is not sold as a medical device and is not intended to be used to diagnose any disease or condition, nor should it be used in the mitigation, treatment, or prevention of any disease or condition. The Sphere device is a key component to the Synexis® Microbial Reduction System.

Legal Notice

While every attempt is made to ensure the accuracy of the information contained in this manual, Synexis® accepts no liability for errors or omissions, or any consequences deriving from the use of information contained herein. This Sphere manual is provided “as is” and without any representation, term, condition or warranty of any kind, either express or implied. To the extent permitted by law, Synexis® shall not be liable to any person or entity for any loss or damage which may arise from the use of this manual. We reserve the right at any time and without any notice to remove, amend or vary any of the content which appears herein.

Patent Information

8,168,122 | 8,685,329 | 9,034,255 | D744,627 | 9,370,592 | 9,808,013 | D814006 | 9,924,722 | 10,188,766 | 10,232,076 | 10,285,382 | 10,299,482 | 15/567,564 | 15/570,677 | 15/866,208 | 29/637,841 | 16/177,592 | 16/271,331 | 62/833,181 | 16/387,382 | 16/431,032 | 62/914,838 | 16/743,809 | 63/010,659 | 15/866,198
Additional patents pending.



Your Synexis®
Sphere DHP System
is Assembled in the USA!

Welcome

Thank you for choosing Synexis, developers of Dry Hydrogen Peroxide (DHP™) and this Sphere device.

Before using the DHP system, please take a few minutes to:

- ✓ **Familiarize yourself with the Sphere device**
- ✓ **Familiarize yourself with the installation steps and required tools**
- ✓ **Inspect your system and parts**

Please contact your Account Representative for questions or additional information.

Included Parts

- ✓ 1 Synexis® Sphere device
- ✓ 1 Custom UV-A Bulb
- ✓ 1 Filter Assembly (x1 Carbon Filter, x1 MERV 11 Filter)
- ✓ 1 Power Cord
- ✓ 1 Quick Start Guide
- ✓ 2 Torx-10 Screwdrivers
- ✓ 1 Stand (already installed) or a wall mount bracket

After opening the box, unpack and inspect your device for damage.

DO NOT OPERATE THIS UNIT IF ANY DAMAGE IS NOTED. If the unit is damaged, contact your Synexis Account Representative.

SPHERE

System Specifications

The Sphere is a portable device designed for deployment with or without an inaccessible HVAC system. The Sphere can be mounted virtually anywhere and requires only a standard 120 VAC outlet.

| Specifications | |
|-------------------------|--|
| Weight | 14 lbs. |
| Material | ABS |
| Color | White and Gray |
| Mounting Options | Desktop (Shown), Wall Mount |
| Dimensions | Width: 18.7" (47.5 cm) Height: 18.7" (47.5 cm) Depth: 7.7" (17.8 cm) |

| Electrical Requirements | |
|-------------------------|--------------------|
| Input Voltage | 120 VAC / 60 Hz US |
| Current | 0.73 Amps |

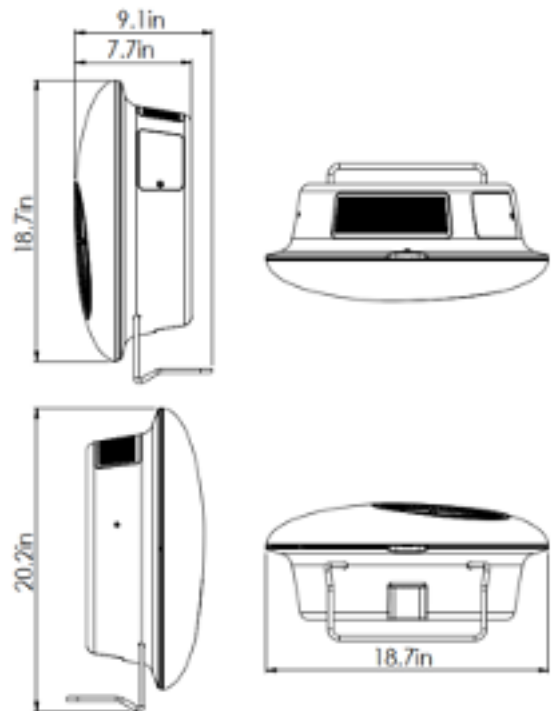
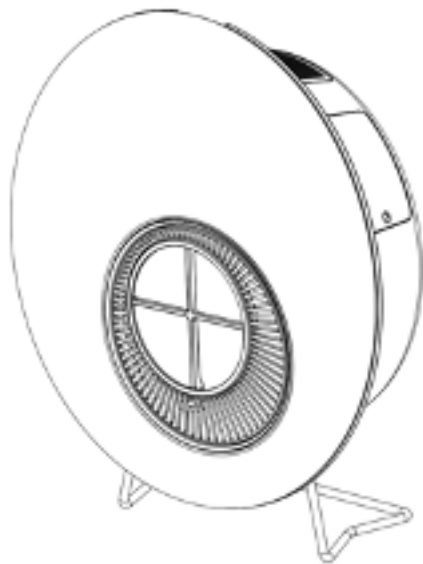

General Safety Instructions

The Sphere is an electrical device. Please read the safety instructions and considerations before use and take the necessary precautions to reduce the risk of fire, electric shock or injury. **The DHP Limited Warranty applies only if the unit is used in accordance with these instructions.**

- ✓ Use the grounded three-prong power cable provided with your device. The plug fits securely into a grounded three-prong outlet. Do not alter the plug in any way.

WARNING: Electrical shock can cause personal injury or death.

WARNING: This device is designed for indoor installation only.

WARNING: Do not allow the device to become clogged with dust or other debris. Check it regularly and replace the catalytic sail or filter if they become clogged.

Device Placement

- Select a location where the air intake and top grille are not obstructed.
- Do not block the air openings.
- Select a dry location. Do not use outdoors or in a wet environment.
- Do not submerge the device in water.
- Do not place fingers and/or objects into the inlet or supply vents.
- Do not allow children or pets to have unsupervised access to this device.
- Do not use any combustible or flammable items on or near this device.
- Do not spill or spray any liquids or aerosols into this device or on the Sail.
- Do not place this device near a heat source.
- Do not sit on or place any object on this device.

Installation

The Sphere device includes filters (carbon & MERV 11), fan, and one non-germicidal UV-A bulb.

Getting to know your device:

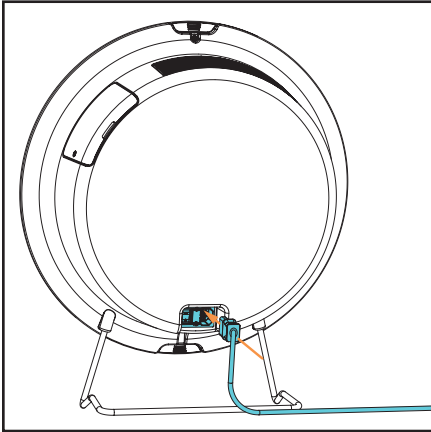

The power cord and power switch are located on the back of the device.

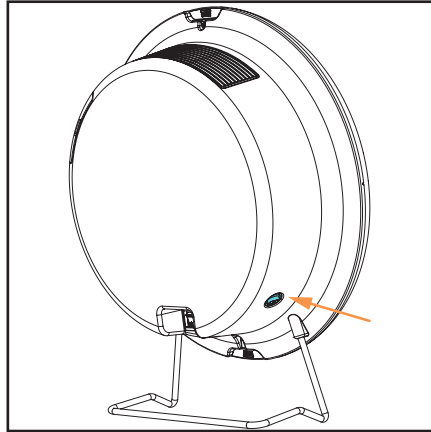

To adjust the device airflow, use the fan speed control switch located on the back of the device.

Removing the cover:

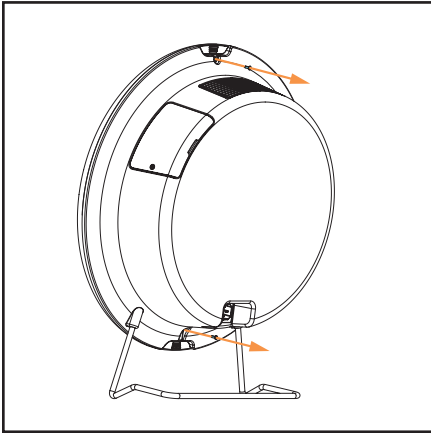

Remove the safety screws at the top and bottom.

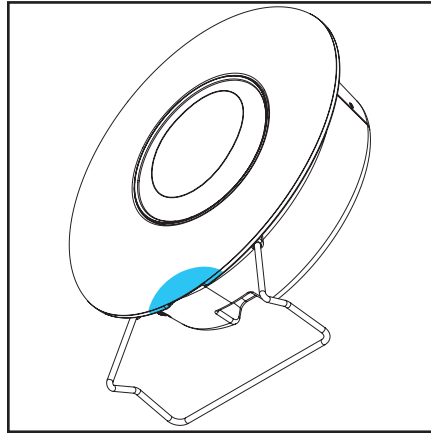

Hold the bottom of the device.

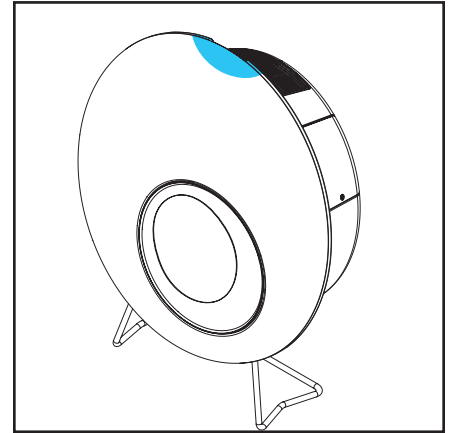

Grab the recess on the top of the device.

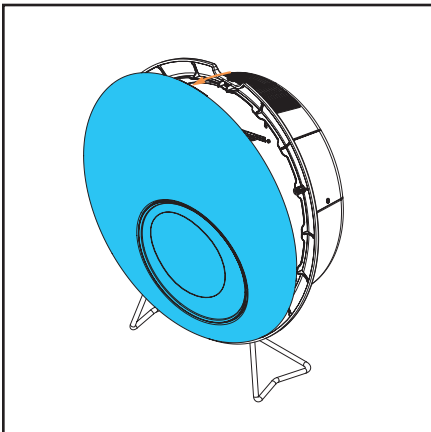

Pull the top and bottom of the cover to disengage the magnets.

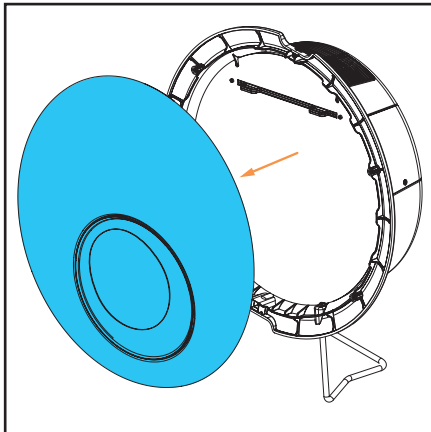

Remove the cover.

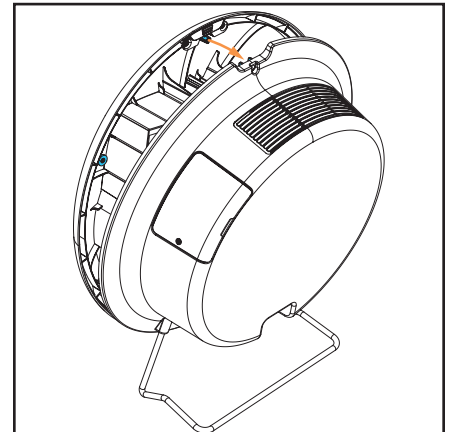

To put the cover back on, position the top and bottom pins over the slots. Let the magnets reengage. Fasten the safety screws.

Installation (cont.)

Inserting the sail:

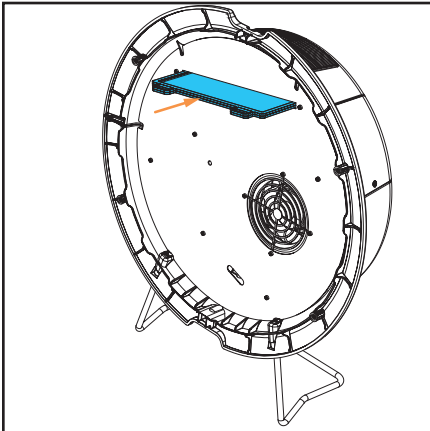

Hold tabs and insert the sail flat and horizontally into the slot near the top of the device. It does not matter which direction the sail is installed.

Replacing the sail:

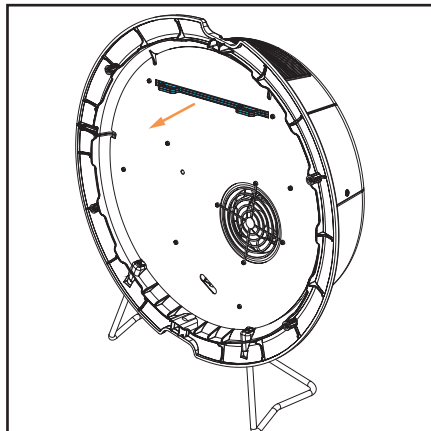

Hold the tabs of the sail and pull towards you.

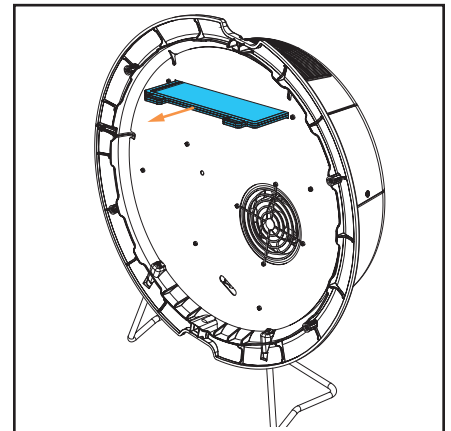

Remove and insert new sail.

Replacing the filters:

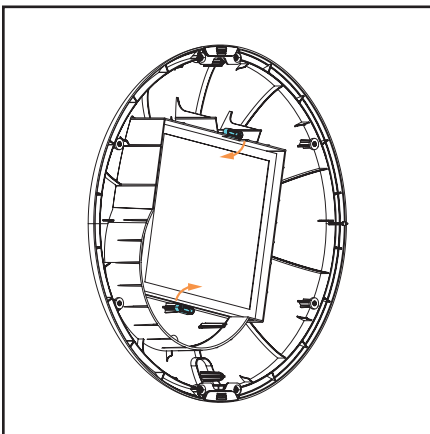

Turn the tabs 90 degrees.

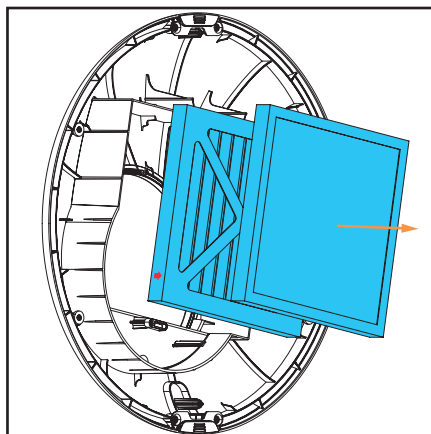

Remove the old filters and replace with new ones*.

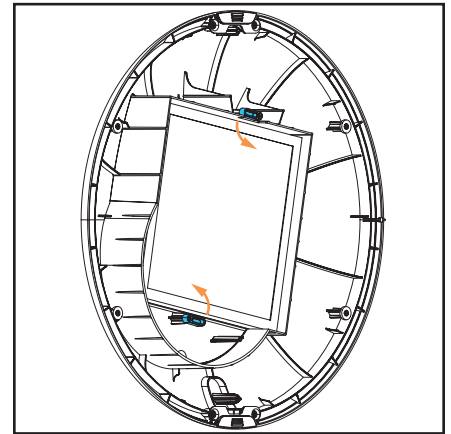

Turn tabs 90 degrees to secure the new filters in place.

**The pleated MERV 11 filter (white or blue) is placed on the bottom with the arrows pointing towards the fan. The carbon filter (black) is placed on top, closest to the fan. The carbon filter can be installed in any direction.*

Installation (cont.)

Inserting or replacing the bulb:

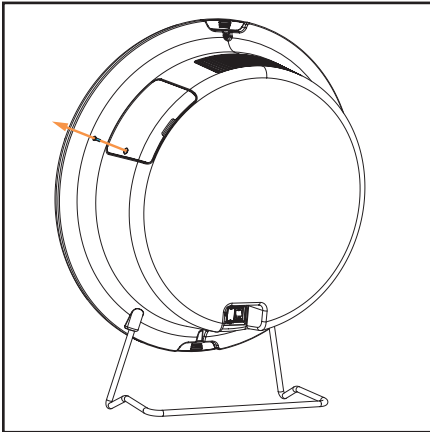

Remove the safety screw on the bulb cover.

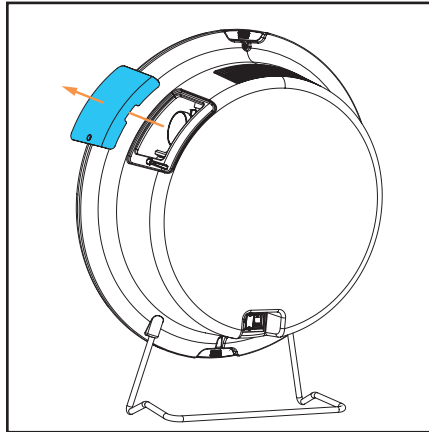

Remove bulb cover.

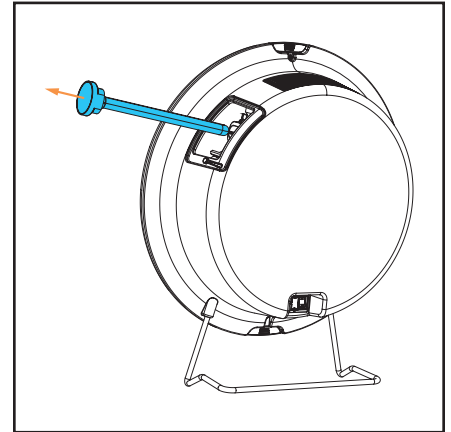

Remove bulb if already inserted.

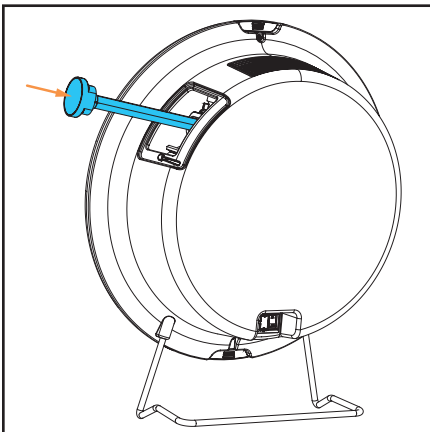

Align the 4 pins to the female socket connectors and insert the new bulb.

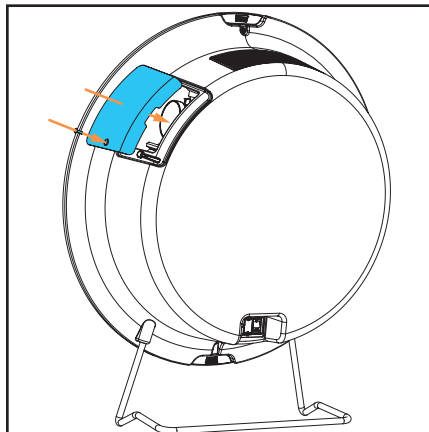

Replace bulb cover and fasten the screw.

Plug in and power the device on.

For wall mount instructions go to www.synexis.com/manuals

Troubleshooting

If the fan does not operate, contact your Account Representative or Synexis directly at 844-352-7680 for assistance.

Maintenance

To keep your device(s) in top condition, we recommend routine cleaning. *If your purchase of the Synexis® Microbial Reduction System includes a maintenance contract, the following recommendations are handled by Synexis Field Engineers during regular scheduled visits.*

- **Bulb Replacement:** The UV-A bulb should maintain the same intensity no matter the speed of the fan. Bulb is warranted for 2 years.
- **Filter Cartridge and Sail Replacement:** Filter cartridges and sails are replaced using the typical schedule below. Each sail comes pre-packaged in a food-grade plastic bag to maintain quality before use. For best performance, the sail should not be removed from the bag until it is time to insert it into the device. The filters and sail can be disposed of in regular trash or as recyclable fiber and plastic (frame and polyester fabric). No special handling conditions are required.

Sail Replacement

- First 7-14 days after first turning device on. This is called the Control Phase and is when a Synexis System is first introduced to a new environment and level of bioburden.
- Every 3 months* (once per quarter)

Filter Replacement

- **MERV 11 filter:**
 - First 7-14 Days (MERV 11 filter ONLY) after first turning device on. This is called the Control Phase and when the Synexis System is first introduced into a new environment and new level of bioburden.
 - Every 3 months** (once per quarter)
- **Carbon Filter:**
 - Every 6 months**

* Complex environments might require a more frequent sail change. This is identified on the front-end of a project and would be detailed in the agreement.

** Complex environments (such as industrial applications) involve higher levels of particulates in the air. Under such conditions, filters may need to be changed on a 'as needed basis'.

Do not try to repair or adjust any of the electrical components in your Sphere device. Contact Synexis for assistance.

WARNING: UV-A bulbs contain a small amount of mercury similar to any fluorescent bulb. Check with your local waste management authority for disposal or recycling requirements. Additional disposal and recycling information can be found at: www.lamprecycle.org.

Getting the most from your DHP System

It is important to install the proper number of units for the size and configuration of your space. In some cases, multiple Synexis devices will be necessary. Be sure to change the sail according to the recommended replacement schedule. Leave unopened sails in their plastic bag and store them in a dark, dry location until you need to replace the current sails in your device.

Close your windows and outside doors

The Sphere is designed for enclosed space, so it is important to keep all external windows and doors closed as much as possible. Open windows and/or doors can significantly reduce the efficiency of your system by allowing the DHP to dissipate out of the facility.

Run your Synexis System 24 hours a day

The Sphere is designed to operate 24 hours a day, 7 days a week. DHP is meant to be a continuous clean technology as opposed to a temporary clean technology. The DHP molecule is delicate and safe at low concentration. Producing it continuously ensures a proper equilibrium concentration in your space for effective decontamination.

Safety Considerations

Please read, understand, and follow all the safety information contained in these instructions prior to use of the Sphere device. Retain these instructions for future reference.

To reduce the risk associated with hazardous voltage, fire, and/or explosion:

- Plug the power cord correctly and tightly into a properly rated electrical outlet.
- Do not use the device if the power cord is frayed or otherwise damaged.
- Do not touch the power cord with wet hands.
- Do not use outdoors or in a wet environment. This device is for indoor, dry location use only.
- Do not submerge the DHP system in water.
- Do not use any combustible or flammable items on or near the DHP system.
- Do not spill or spray any liquids or aerosols into the device or on the Sail.
- Do not block any air vents during use.
- Do not place the DHP system near a heat source.
- Do not modify or attempt to modify this device.
- Do not disassemble the device beyond filter and sail replacement as part of regular maintenance.

To reduce the risk associated with various hazards:

- Read and understand the operating manual before using the device.
- Do not allow children or pets to have unsupervised access to this device.
- Do not sit on or place any object on this device.



synexis[®]

Synexis LLC

11711 W 79th St | Lenexa, KS | 66214

+1 (844) 352-7680

info@synexis.com